

Remote power switch

LED-RPS-CL-R

Release Version 1.3 (Feb. 2024)



Important Information

Safety Precautions and Maintenance



FOR OPTIMUM PERFORMANCE, PLEASE NOTE
THE FOLLOWING WHEN SETTING UP AND
USING THE REMOTE POWER SWITCH:

About the Symbols

To ensure safe and proper use of the product, this manual uses a number of symbols to prevent injury to you and others as well as damage to property. The symbols and their meanings are described below. Be sure to understand them thoroughly before reading this manual.

 WARNING	Failing to heed this symbol and handling the product incorrectly could result in accidents leading to major injury or death.
 CAUTION	Failing to heed this symbol and handling the product incorrectly could result in personal injury or damage to surrounding property.

Examples of symbols

	⚠ Indicates a warning or caution. This symbol indicates you should be careful of electric shocks.
	⊘ Indicates a prohibited action. This symbol indicates something that must be prohibited.
	● Indicates a mandatory action. This symbol indicates that the power cord should be unplugged from the power outlet.

Be sure to read the following before using the product to use it correctly and safely.

WARNING

 Do not apply vibrations or shocks to the product.

 Do not install the product to unstable locations or locations subject to vibrations.

 Always ask a technician to perform the installation.

 Do not connect the cables with wet hands. Otherwise, it may cause an injury or an electrical shock.

 Do not repair or modify the product yourself. Otherwise, it may cause an injury, a fire or an electrical shock.

 In case of thunder, do not touch the power cord. Otherwise, it may cause an electrical shock.

 Connect the product to the correct voltage. If the product is connected to a voltage other than the specified voltage, it may lead to a fire or an electrical shock.

 In case of a malfunction (nothing is displayed on the screen, etc.) or if smoke, abnormal heat, or a strange sound or odor is generated, turn the power off and immediately ask a technician or your retailer for repair.

 Do not put objects into the product. Otherwise, it may cause a fire or an electrical shock.

 In case the product is in contact with water or another liquid, immediately disconnect the power supply and stop using the product. If you continue using the product in that state, it may lead to a malfunction, a fire, or an electrical shock.

 The device must be installed in a housing / switch cabinet in the end application and must not be accessible during operation.

CAUTION

 When connecting the power cord to the product's AC IN terminal, make sure the connector is fully and firmly inserted.

 Do not damage the power cord. Do not put heavy objects on it, place it near heaters, pull it with excessive strength, or apply a strong force on it while it is bent. A damaged power cord may cause a fire or an electrical shock.

 Do not install the product in narrow places where heat tends to build up.

 Do not use the product in an environment with low heat dissipation. Otherwise, it may cause a malfunction.

 Do not use the product in a vehicle or another means of transportation.

 Do not place the product under direct sunlight or near heaters.

 This product is designed to be used indoors. Do not use it outdoors. Otherwise, it may cause a malfunction.

 Do not use or store the product in the following places.

- Near heaters
- Places with lots of humidity or dust, or places subject to oily smoke
- Places where water or oil may splash
- Places with lots of corrosive gases, such as near hot springs
- Places where the product may freeze
- Do not place the product on its side, face down, or upside down.
- Places with lots of vibrations

 If you will not be using the product for a long time, disconnect it from the power distributor for safety purposes.

 Disconnect the power supply when performing maintenance.

 Install the product in accordance with local laws and regulations.

This product can only be serviced in the country where it was purchased.

Parts Name and Functions

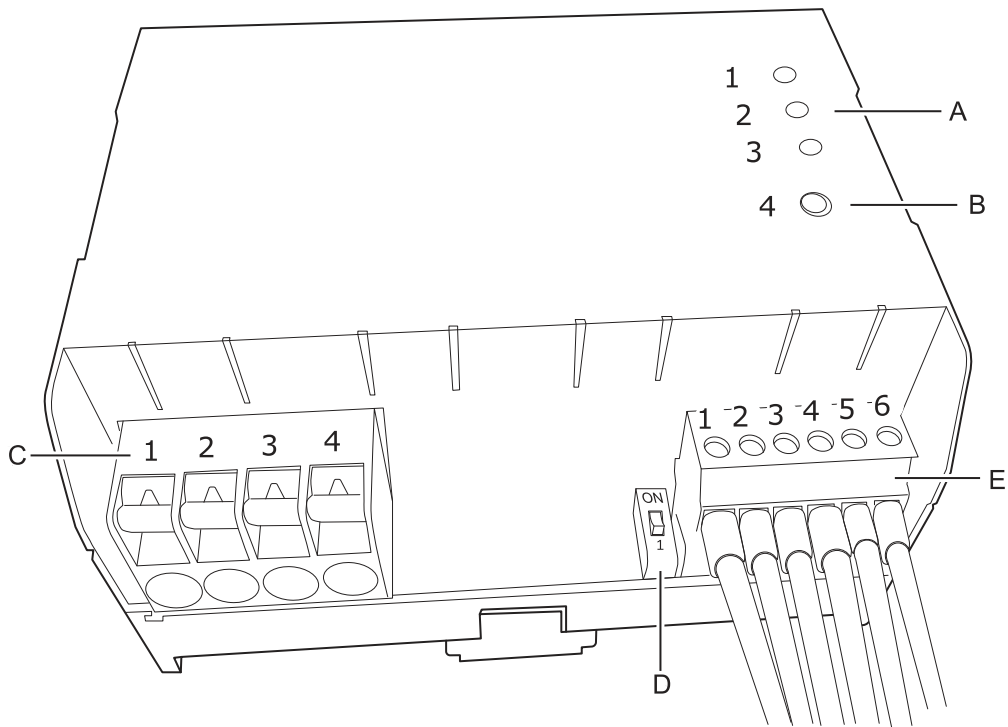

A: LED indicators

Nr	LED Indicator	LED state	Explanation
1	ON/OFF	ON	AC OUT on
		OFF	AC OUT off
		Flashing	AC OUT will switch after cooldown delay
2	REMOTE	ON	Remote mode
		OFF	Local mode
3	STATUS	ON	Normal operation
		Fast Flashing	Device receives data from RS-485 port
		Flashing (1s ON / 1s OFF)	Temperature error or DC voltage error

B: Button

Nr	Name	Explanation
4	MODE	<p>Press and hold the switch for 3 seconds to switch between modes (remote mode/local mode).</p> <p>Remote mode: Switch AC OUT (ON/OFF) using RS-485 communication or "Control In" pin</p> <p>Local mode: A short button press switches the AC OUT between ON and OFF.</p> <p>Note: The device always starts in remote mode</p>

C: AC connector

Nr	Pin name		Explanation
1	L	↑	Supply line live (L)
2	N		Supply line neutral (N)
3	L	↓	Connect to LED device live (L)
4	N		Connect to LED device neutral (N)

Note

The protective ground wire (PE) must be connected with a separate clamp

D: RS-485 Termination switch

Set the switch to ON, for the first and the last device in the chain
For the other devices set the switch to OFF.

E: Control connector

Nr	Pin name	Name	Explanation
1	+	DC12 V	Connect to +12V DC power supply
2	B	RS-485(-)	Use this connector when controlling the device using RS-485 communication
3	A	RS-485(+)	
4	⊥	GND	
5	↑	Control In	Switch AC OUT with a potential free switch contact Contact Closes: Switch the AC OUT ON Contact Opens: Switch the AC OUT OFF
6	↓	Control Out	The "Control Out" drives the "Control In" of the next device. The next device switches the "AC OUT" ON with a delay of aprox. 1.8 sec (see schematic on page 6 - I/O port control)

Cable Information

AC connector

The following cables can be used.

Conductor cross section rigid	1.5 mm ² to 6 mm ²
Conductor cross section flexible	1.5 mm ² to 6 mm ²
Stripping length	10 mm

Note

Press the orange levers, then plug in the cables.

To disconnect them, unplug the cables while pressing the orange levers.

Control connector

The following cables can be used.

Conductor cross section rigid	0.14 mm ² to 1.5 mm ²
Conductor cross section flexible	0.14 mm ² to 1.5 mm ²
2 conductors with same cross section, solid	0.08 mm ² to 0.5 mm ²
2 conductors with same cross section, flexible	0.08 mm ² to 0.75 mm ²
Conductor cross section AWG	28 to 16
Stripping length	7 mm

Note

Loosen and tighten the screws with a slot screwdriver (2 mm).

Tightening torque: 0.22 N•m to 0.25 N•m.

Wiring Diagrams

RS-485 control

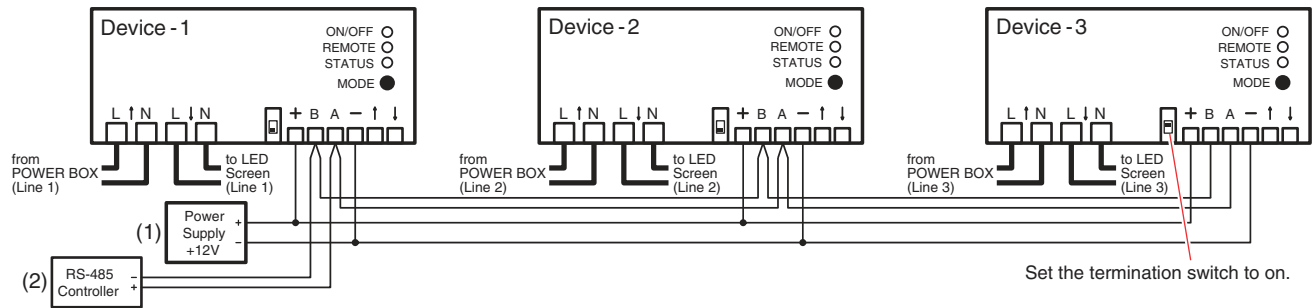

I/O port control

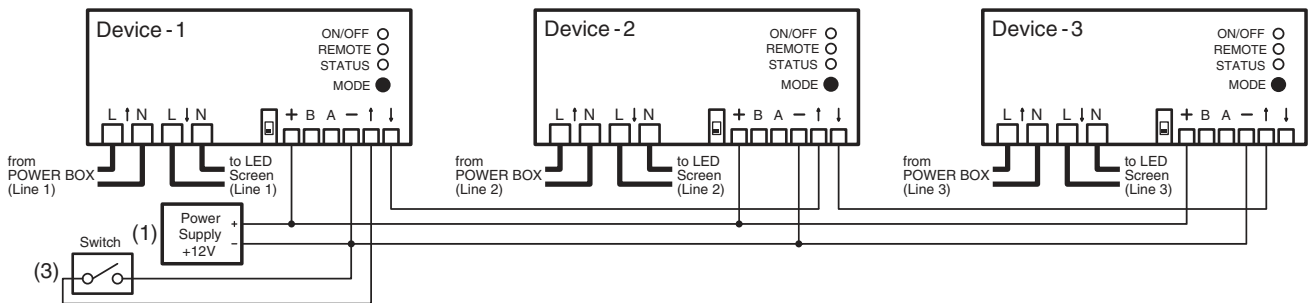

RS-485 control + I/O port control

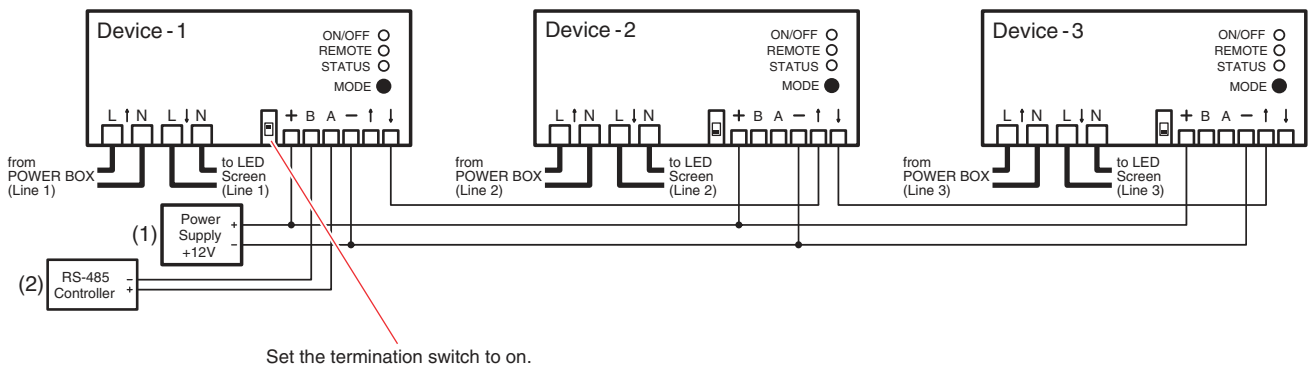

Note

- (1), (2), (3) Power Supply, RS-485 Controller and Switch are not included in the scope of delivery and has to be purchased externally from a third-party provider.
- (2) The RS-485 Controller can be any device, which communicates via RS-485 protocol (e.g. PC, Mediacontroller, KNX or EIB device)
- (3) Switch can be for example a potential free output of an KNX or EIB device.

Mounting on DIN rail

Using 35mm DIN rail.

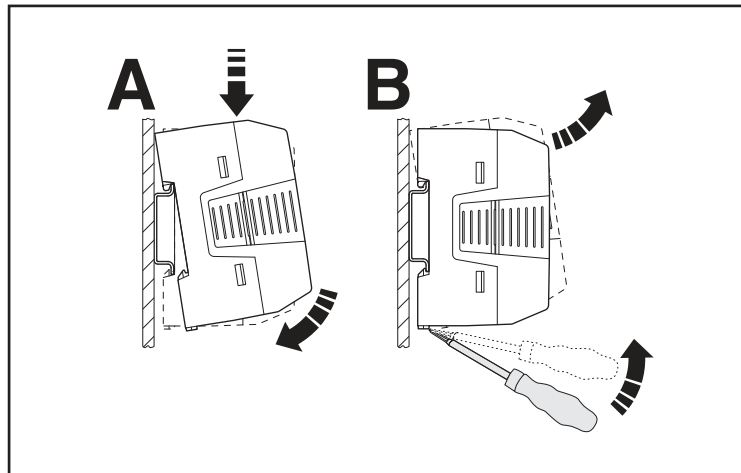

Mounting

Place the upper keyway hooks onto the top edge of DIN rail. (A)

And then, push toward the mounting surface.

check that it is attached securely.

Removal

Use a suitable screwdriver to release the locking mechanism of the device. (B)

Carefully lift it off the DIN rail.

Address setting

Method for two devices

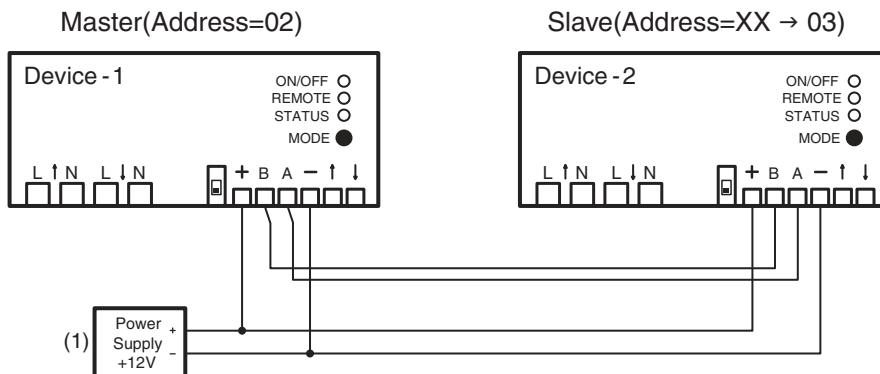

Procedure:

1. Connect according to diagram above.
2. Switch on the DC Power supply.
3. Press the MODE button of the master device within 10 sec after turning the power on and keep the button pressed for at least 15 sec.

Note

- (1) Power Supply is not included in the scope of delivery and has to be purchased externally from a third-party provider.
The slave device address will be set to master address + 1.
The slave device will confirm the new address with 6-times fast flashing of the "STATUS" LED.

Method for more devices

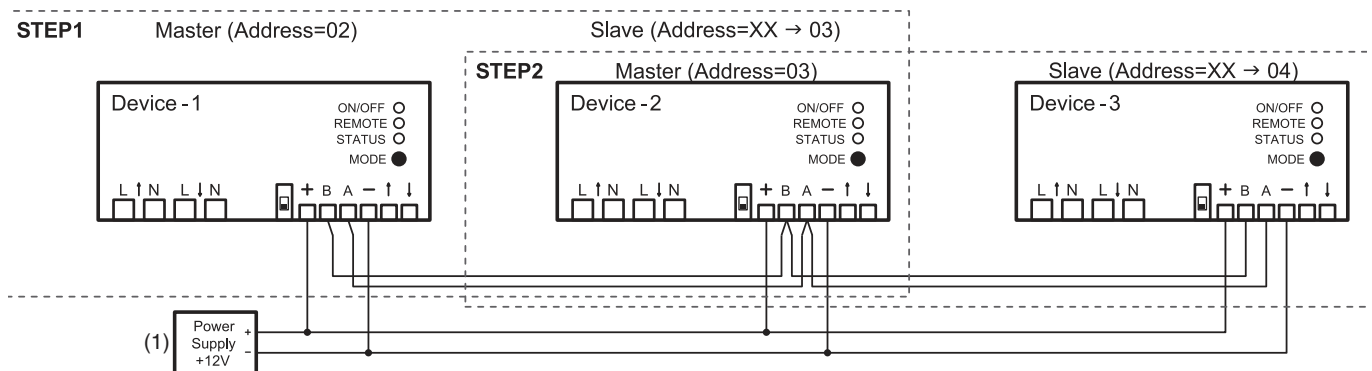

1. Connect according to diagram above STEP-1 (Device-1 = Master, Device-2 = Slave).
2. Switch on the DC Power supply.
3. Press the MODE button of the master device within 10 sec after turning the power on and keep the button pressed for at least 15 sec.
4. Connect according to diagram above STEP-2 (Device-2 = Master, Device-3 = Slave) .
5. Switch on the DC Power supply.
6. Press the MODE button of the master device within 10 sec after turning the power on and keep the button pressed for at least 15 sec.

Note

- (1) Power Supply is not included in the scope of delivery and has to be purchased externally from a third-party provider.
The slave device address will be set to master address + 1.
The slave device will confirm the new address with 6-times fast flashing of the "STATUS" LED.

Communication Protocol

Serial settings

Baud Rate	19200bps
Data	8 bits
Stop Bit	1 bit
Flow control	None

Sending (PC → LED-RPS-CL-R)

	Start of Frame (1-byte)	Source Address (2-byte)	Dot (1-byte)	Destination Address (2-byte)	Dot (1-byte)	Command	Dot (1-byte)	Checksum (2-byte)	End of Frame (1-byte)
ASCII	L_F	01 ^(*1)	.	02 ^(*2)	.	reqps	.	54	C_R
HEX	0x0A	0x30 0x31	0x2E	0x30 0x32	0x2E	0x72 0x65 0x71 0x70 0x73	0x2E	0x35 0x34	0x0D

Receiving (LED-RPS-CL-R → PC)

	Start of Frame (1-byte)	Source Address (2-byte)	Dot (1-byte)	Destination Address (2-byte)	Dot (1-byte)	Command	Dot (1-byte)	Checksum (2-byte)	End of Frame (1-byte)
ASCII	L_F	02 ^(*2)	.	01 ^(*1)	.	ps:on	.	23	C_R
HEX	0x0A	0x30 0x32	0x2E	0x30 0x31	0x2E	0x70 0x73 0x3A 0x6F 0x6E	0x2E	0x32 0x33	0x0D

(*1) "01" is set for the PC address.

(*2) The address of the LED-RPS-CL-R is "02" by default.

Checksum calculation

The values from "Start of Frame" to "End of Command" are added and the last byte of the hexadecimal sum is displayed in ASCII.

Example: With 0A(LF) 30(0) 31(1) 2E(.) 30(0) 32(2) 2E(.) 72(r) 65(e) 71(q) 70(p) 73(s)

$0x0A + 0x30 + 0x31 + 0x2E + 0x30 + 0x32 + 0x2E + 0x72 + 0x65 + 0x71 + 0x70 + 0x73 = 0x0354$

Consequently, the checksum expressed in ASCII is "54".

Command list

Sending command	Function	Sending example	Response command		Reception example
pwr#on	Sets AC OUT to on.	$t_F01.02.pwr\#on.82^{C_R}$	No reply		No reply
pwr#of	Sets AC OUT to off.	$t_F01.02.pwr\#of.7A^{C_R}$	No reply		No reply
reqps	Requests the state of AC OUT.	$t_F01.02.reqps.54^{C_R}$	ps:on	AC OUT is on.	$t_F02.01.ps:on.23^{C_R}$
			ps:of	AC OUT is off.	$t_F02.01.ps:of.1B^{C_R}$
			ps:wa	AC OUT delayed switch on	$t_F02.01.ps:wa.1E^{C_R}$
reqcm	Requests the operating mode.	$t_F01.02.reqcm.41^{C_R}$	cm:rem	Operating in the remote mode.	$t_F02.01.cm:rem.77^{C_R}$
			cm:loc	Operating in the local mode.	$t_F02.01.cm:loc.71^{C_R}$
reqst	Requests the state of the device.	$t_F01.02.reqst.58^{C_R}$	ds:ok	Operates normally.	$t_F02.01.ds:ok.14^{C_R}$
			ds:er	Error	$t_F02.01.ds:er.11^{C_R}$
reqsv	Requests the voltage of the DC power.	$t_F01.02.reqsv.CF^{C_R}$	usv:IIIDD III = Integer part of the voltage value (3 digits) DD = Decimal part of the voltage value (2 digits)		$t_F02.01.usv:01250.B9^{C_R}$ usv:01250 = 12.50 V
requss	Requests the state of the DC power.	$t_F01.02.requss.CC^{C_R}$	uss:ok	Within the normal voltage range	$t_F02.01.uss:ok.98^{C_R}$
			uss:er	Voltage detection error	$t_F02.01.uss:er.95^{C_R}$
			uss:ov	Voltage error (high voltage)	$t_F02.01.uss:ov.A3^{C_R}$
			uss:lo	Voltage error (low voltage)	$t_F02.01.uss:lo.99^{C_R}$
reqt1v	Requests the temperature.	$t_F01.02.reqt1v.8C^{C_R}$	t1v:SIIDD S = Sign (+ or -) III = Integer part of the temperature value (3 digits) DD = Decimal part of the temperature value (2 digits)		$t_F02.01.t1v:+031.25.A4^{C_R}$ t1v:+031.25 = 31.25°C
reqt1s	Requests the temperature state.	$t_F01.02.reqt1s.89^{C_R}$	t1s:ok	Within the normal temperature range	$t_F02.01.t1s:ok.55^{C_R}$
			t1s:er	Temperature sensor error	$t_F02.01.t1s:er.52^{C_R}$
			t1s:ov	Temperature error (high temperature)	$t_F02.01.t1s:ov.60^{C_R}$
reqrt	Request the total time with AC OUT on.	$t_F01.02.reqrt.57^{C_R}$	rt:HHHHHH HHHHHH = The number of hours expressed as a 6-digit hexadecimal number		$t_F02.01.rt:000100.6A^{C_R}$ rt:000100 = 256 hours rt:002710 = 10000 hours
reqsv	Requests the software version.	$t_F01.02.reqsv.5A^{C_R}$	sv:XXX XXX = software version (3 digits)		$t_F02.01.sv:001.DD^{C_R}$ sv:001 = version 001
reqhv	Requests the hardware version.	$t_F01.02.reqhv.4F^{C_R}$	hv:AAA_BBB_CCC AAA = Hardware index (3 digits) BBB = Hardware version (3 digits) CCC = Production key (3 digits)		$t_F02.01.hv:05c_002_001.CA^{C_R}$
reqhn	Requests the model name.	$t_F01.02.reqhn.47^{C_R}$	hn:LED-RPS-CL-R		$t_F02.01.hn:LED-RPS-CL-R.6B^{C_R}$

Explanations about operations

(1) AC OUT control and operation after turning the devices on

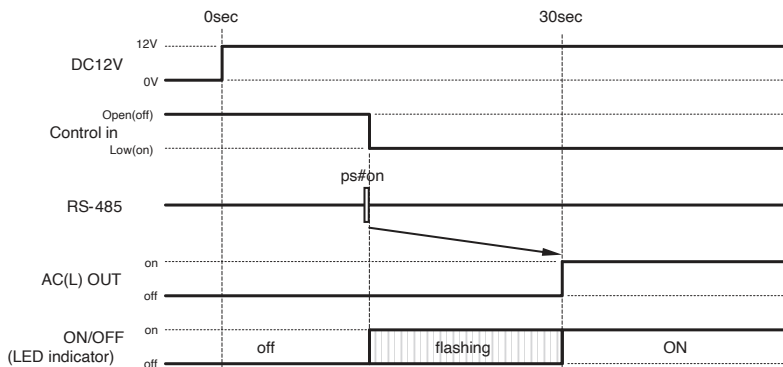

AC OUT turns on 30 seconds after the devices have been turned on when AC OUT is set to on using Control in or RS-485 within 30 seconds after turning the devices on.

In such a case, the ON/OFF LED indicator flashes.

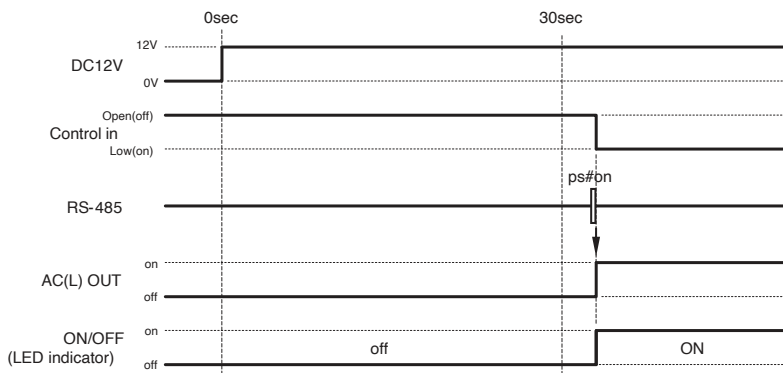

AC OUT turns on immediately when AC OUT is set to on using Control in or RS-485 after 30 seconds have passed after turning the devices on.

(2) AC OUT control and operation

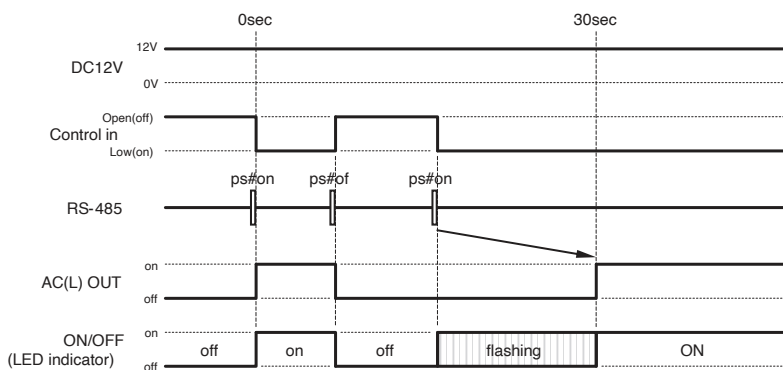

When AC OUT was turned on within 30 seconds after AC OUT had been set to on using Control in or RS-485, AC OUT turns on 30 seconds after AC OUT previously turned on.

In such a case, the ON/OFF LED indicator flashes.

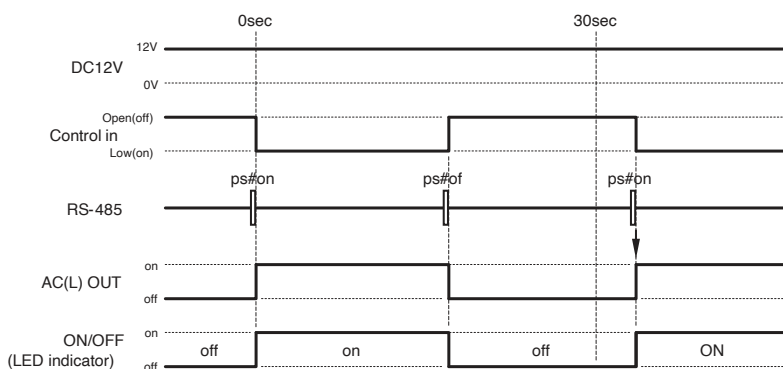

AC OUT turns on immediately when AC OUT was turned on more than 30 seconds after AC OUT had been set to on using Control in or RS-485.

(3) Timing of Control out output

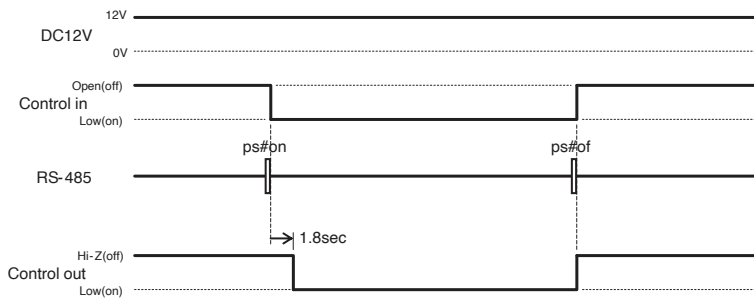

Control out turns on 1.8 seconds after AC OUT is set to on using Control in or RS-485.

Control out turns immediately off when AC OUT is set to off using Control in or RS-485.

(4) Operation when an error occurs

High-temperature protection operation

AC OUT turns off when the internal temperature reaches 60°C or higher and AC OUT turns on again when the internal temperature decreases to 55°C or lower.

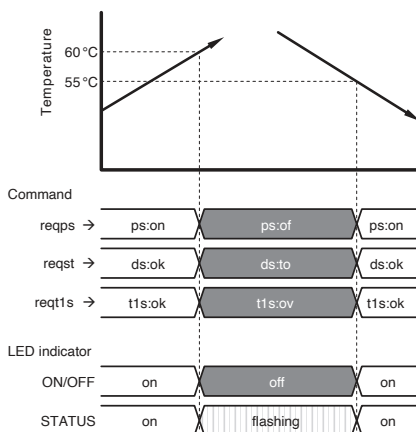

High-voltage protection operation

AC OUT turns off when the voltage reaches 14 V or higher and AC OUT turns on again when the voltage decreases to 13.5 V or lower.

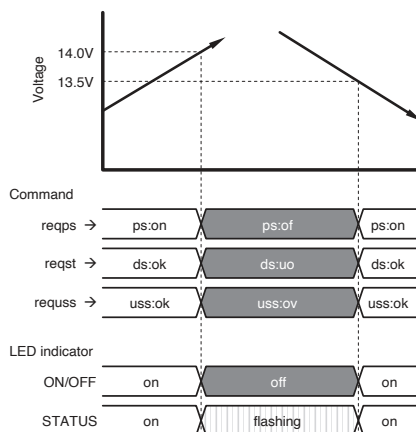

Low-voltage protection operation

AC OUT turns off when the voltage decreases to 10 V or lower and AC OUT turns on again when the voltage increases to 10.5 V or higher.

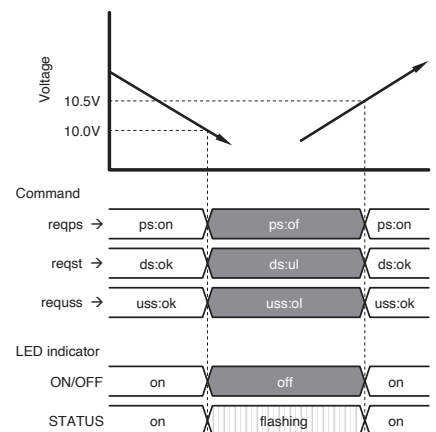

Specifications

AC IN	Input voltage	100 V AC to 240 V AC	
	Input current	Max. 16 A	
	Load capacity	Max. 6000 μ F	
DC IN	Supply voltage	+12 V \pm 1.5 V	
	Power consumption	1,3 W (AC OUT on) 0.3 W (AC OUT off)	
CONTROL		RS-485	
		Control In	Open circuit voltage: 12 V Short circuit current: 2 mA
		Control Out	Open collector output
Operating environment	Temperature	-20 to 40°C	
	Humidity	10% to 80% (without condensation)	
	Altitude	No more than 5000 m	
Storage environment	Temperature	-20 to 45°C	
	Humidity	10% to 85% (without condensation)	
Dimensions		90 x 75 x 51 mm	
DIN rail space requirement		6 TE	
Weight		170 g	

Dimensions

